

Rear Mud Flap Package Installation

Installation Instructions Part Number

23294781

Note: Please read instructions thoroughly before starting.

Rear Mud Flap Kit Contents

Qty	Description
1	Left Hand Splash Guard
1	Right Hand Splash Guard
1	Left Hand Splash Guard Bracket
1	Right Hand Splash Guard Bracket
8	M4.2 x 25 Screw
8	M4.2 U-nut
1	Instruction Sheet

Tools Required

- T15 Screw Driver
- Drill
- 13/64" (5.0mm) Drill Bit
- Awl
- Clean Cloth/Rag
- Isopropyl Alcohol

Installation Procedure

Note: Do not use power tools to install fasteners.

1. Remove the rear wheel and tire. Refer to Vehicle Service Manual.
2. Clean and degrease body panel where splash guards will be located.
3. Using isopropyl alcohol, clean area where tape will contact body panel.

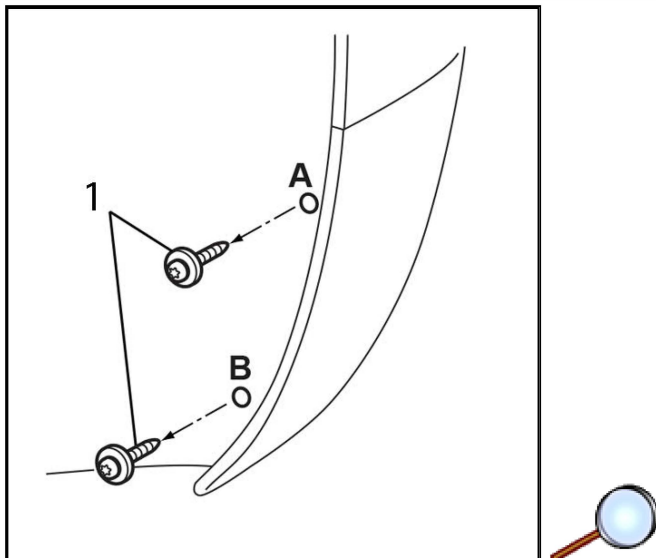

4. Remove existing screw (1) from locations (A) and (B) and retain.

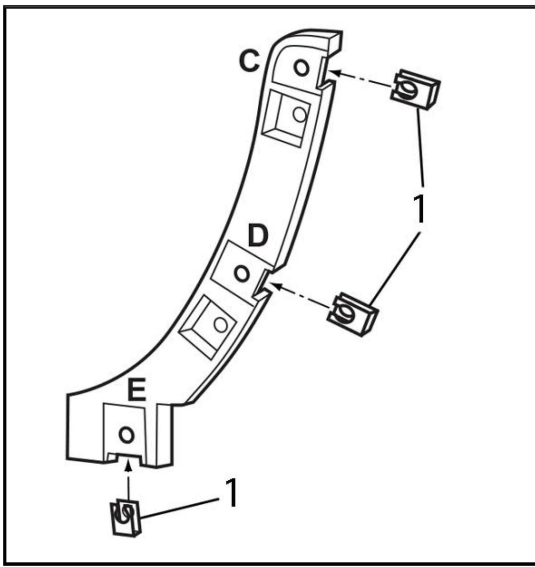

5. Place supplied U-nuts (1) onto supplied bracket at locations (C), (D) and (E).

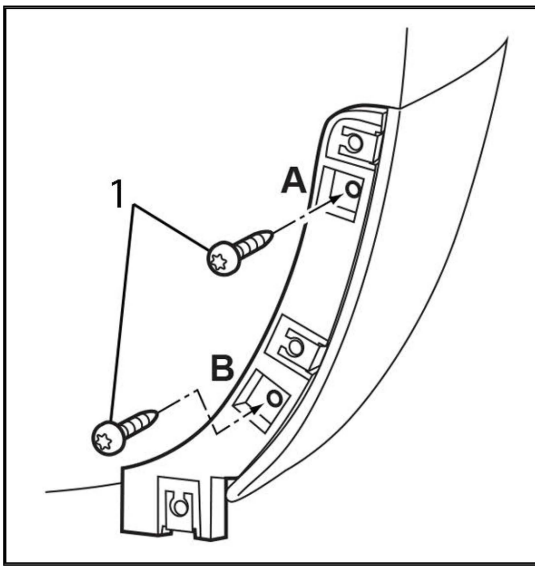

Caution: Use the correct fastener in the correct location. Replacement fasteners must be the correct part number for that application. Fasteners requiring replacement or fasteners requiring the use of thread locking compound or sealant are identified in the service procedure. Do not use paints, lubricants, or corrosion inhibitors on fasteners or fastener joint surfaces unless specified. These coatings affect fastener torque and joint clamping force and may damage the fastener. Use the correct tightening sequence and specifications when installing fasteners in order to avoid damage to parts and systems.

6. Place bracket to vehicle and install supplied screws (1) at locations (A) and (B).

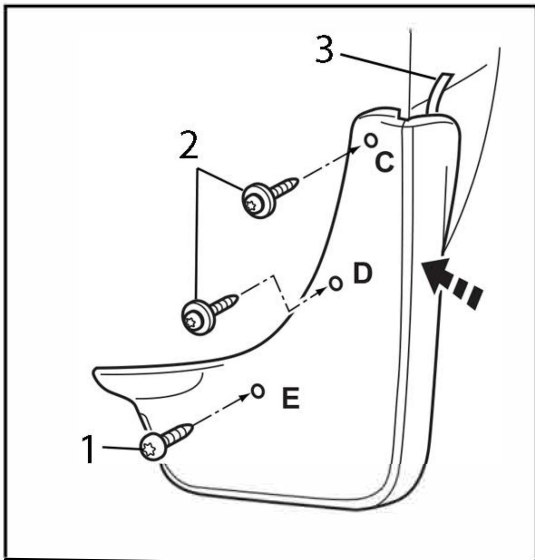

7. Place splash guard assembly to bracket taking care to remove any gaps to the vehicle, make sure red tape pull tab (3) is accessible, and install screws (2) retained from step 4 at locations (C) and (D). Install supplied screw (1) at location (E).

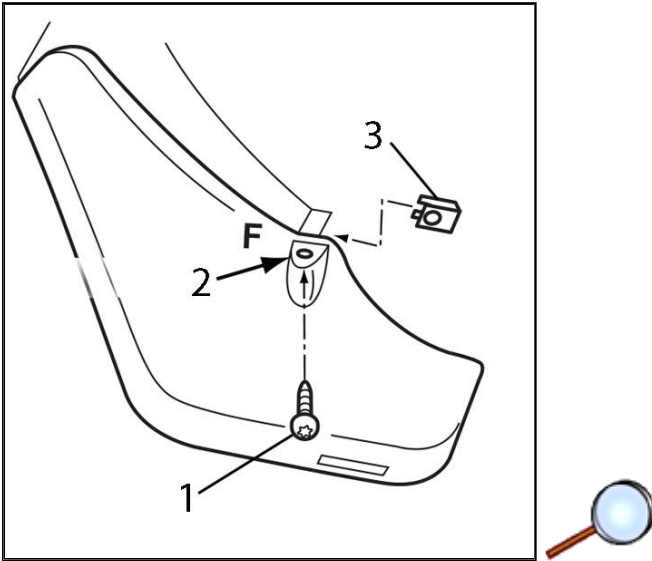

8. While pulling splash guard rearward and inboard to insure no gaps, drill a 13/64" (5.0 mm) hole (2) at location (F). Drill hole through splash guard and fascia.
9. Install supplied screw (1) and U-nut (3) at location (F). U-nut should be used as a nut above the fascia.

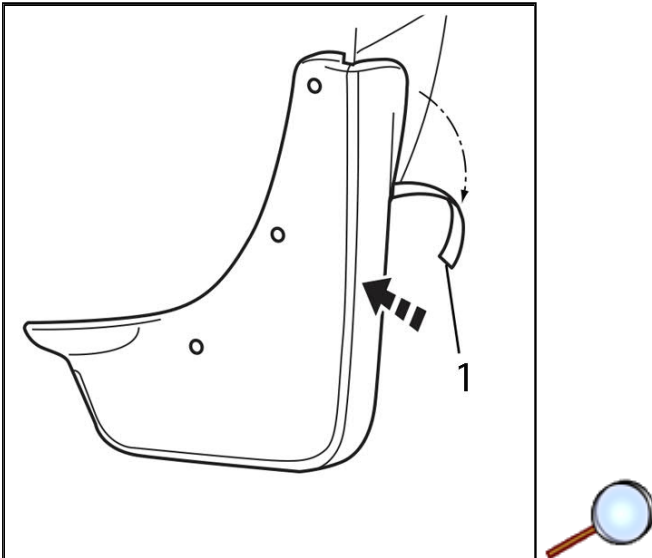

10. Remove tape liner (1) and apply firm pressure to the splash guard along the tape line to adhere the tape to the fender. Hold the firm pressure for a minimum of 60 seconds to properly adhere the tape.
11. Repeat for other side.
12. Guards can be cleaned with any commercially available cleaner.

Note: Maximum torque on M4.2 screw is 3.0 N•m.