

Front Fender Mud Guard Package Installation

Installation Instructions Part Number

84433576

Note: Please read instructions thoroughly before starting.

Front Fender Mud Guard Kit Contents

Qty	Description
1	Left Hand Splash Guard
1	Right Hand Splash Guard
2	M4.2 x 25 Screw
2	Rivet
1	Instruction Sheet

Tools Required

- T15 Torx Bit
- Drill with 13/64" (5.0mm) Drill Bit
- Rivet Gun
- Awl
- Clean Cloth/Rag
- Isopropyl Alcohol

Installation Procedure

Note: Do not use power tools to install splash guard fasteners.

1. Remove front wheel and tire assembly. Refer to [Tire and Wheel Removal and Installation](#) in Vehicle Service Manual.
2. Clean and degrease body panel where splash guards will be located.
3. Using isopropyl alcohol, clean area where tape will contact body panel.

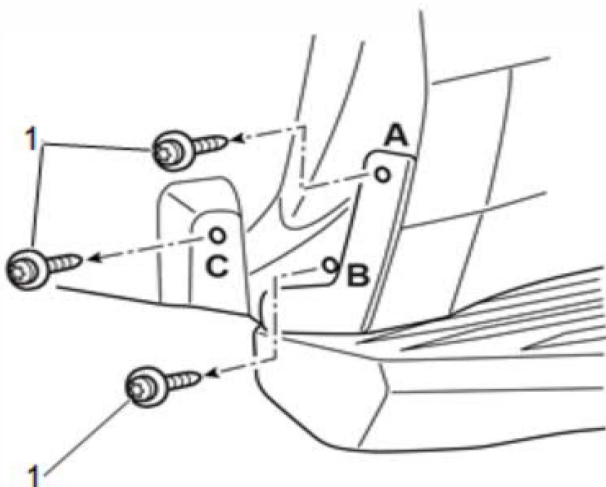

4. Remove existing screws (1) at locations (A), (B) and (C). Retain screws at (A) and (C) and discard (B).

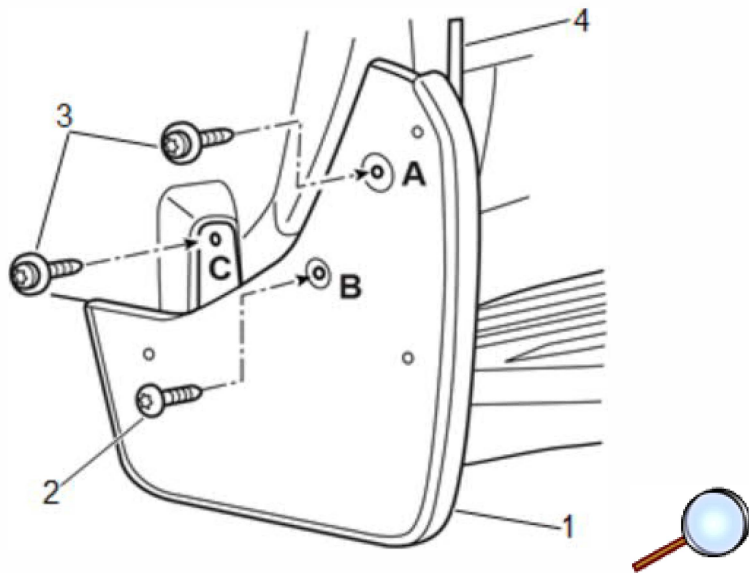

5. Making sure that the tape pull tab (4) is visible, place splash guard (1) to the vehicle taking care to remove any gaps to the vehicle.

Caution: Use the correct fastener in the correct location. Replacement fasteners must be the correct part number for that application. Fasteners requiring replacement or fasteners requiring the use of thread locking compound or sealant are identified in the service procedure. Do not use paints, lubricants, or corrosion inhibitors on fasteners or fastener joint surfaces unless specified. These coatings affect fastener torque and joint clamping force and may damage the fastener. Use the correct tightening sequence and specifications when installing fasteners in order to avoid damage to parts and systems.

6. Install retained screws (3) from step 4 at locations (A) and (C). Use an awl if necessary to align the holes on the splash guard to the vehicle holes.

7. Install supplied M4.2 x 25 screw (2) at location (B).

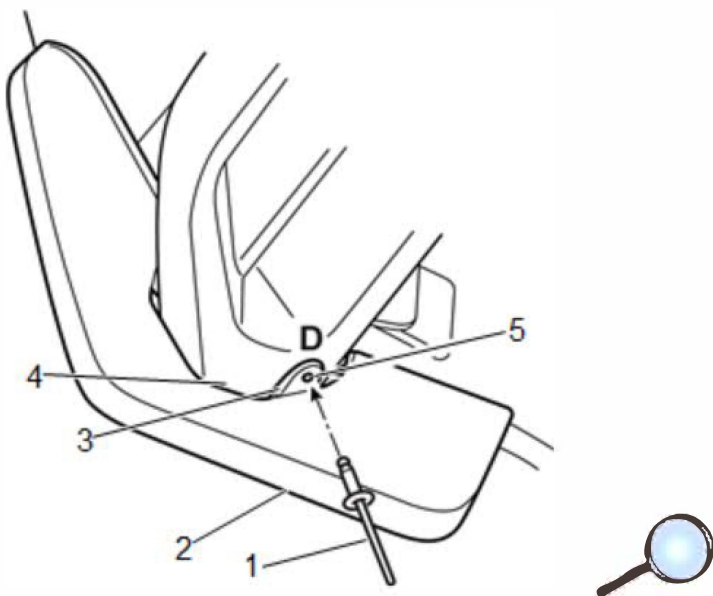

Caution: Always check scale, size and position of all templates before drilling. Failing to do so may cause damage to the vehicle, misalignment of components or the inability to install the accessory.

8. While pulling splash guard (2) rearward and inboard to create a consistent gap around the assist step and a flush fit between the tab (3) and the assist step (4), carefully drill a 13/64" (5.0 mm) hole through the splash guard and assist step using the existing hole (5) at location (D) as a pilot.

9. Install Supplied rivet (1) at location (D).

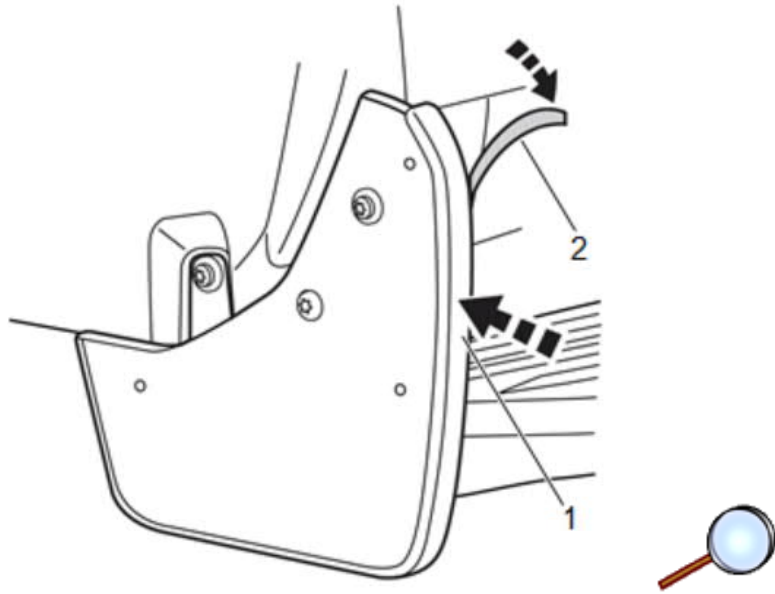

10. Remove tape pull tab (2) and apply firm pressure to the splash guard (1) along the tape line to adhere the tape to the fender. Hold the firm pressure for a minimum of 60 seconds to properly adhere the tape.
11. Install front wheel and tire assembly. Refer to [Tire and Wheel Removal and Installation](#) in Vehicle Service Manual.
12. Repeat for other side.
13. Guards can be cleaned with any commercially available cleaner.
Note: Maximum torque on M4.2 screw is 3.0 N•m.